

CURVEYOR

FIT TIGHT TURNS AND TRANSFERS



The Curveyor curved belt conveyor fits in tight angles and spaces of your food processing plant. Its powered belt turns keep your product moving around turns, corners, and other equipment with minimal maintenance. Tight infeed and outfeed transfers ensure product orientation and integrity with no damage or loss in gaps. The Curveyor is designed for quick yet thorough cleaning and simple maintenance.

- Available with 30-180 degree turn radius
- Bi-directional product flow
- Center-driven powered belt turns
- Tight transfer 5/8" or 7/8" rolling nosebars for smooth, damage-free transfers
- Food-grade sanitary design with open frame and simple belt changes in 30 minutes

COMMON FOOD APPLICATIONS



BAKERY



CANDY



FRESH PRODUCE



FROZEN



READY-TO-EAT



SNACK FOOD



CURVEYOR

FEATURES + SPECS

Key details to help you decide if the Curveyor is right for your operation.

- Natural belt tracking
- Turn Radius: 30-180 degrees
- Max Speed: 200 FPM
- Width: 14-84" (355-2134 mm) effective
- Height: dependent on width, as low as 30" TOB
- Motor/Drive: SEW gearmotor, Stober gearbox/Baldor motor
- Electrical: 230/460 volt standard; 575 volt or 110v optional

OPTIONS

Additional equipment options to customize the Curveyor precisely to your application.

- Dry clean, wash down, and ready to eat (RTE) sanitation levels
- Belts: 2-ply, finger spliced endless, white or blue, high-temp
- Left or right-hand orientation
- Ceiling support frame
- Nose rollers: 5/8" or 7/8" tight transfer, or 2.25" segmented
- Belt scraper (tool-less removal)

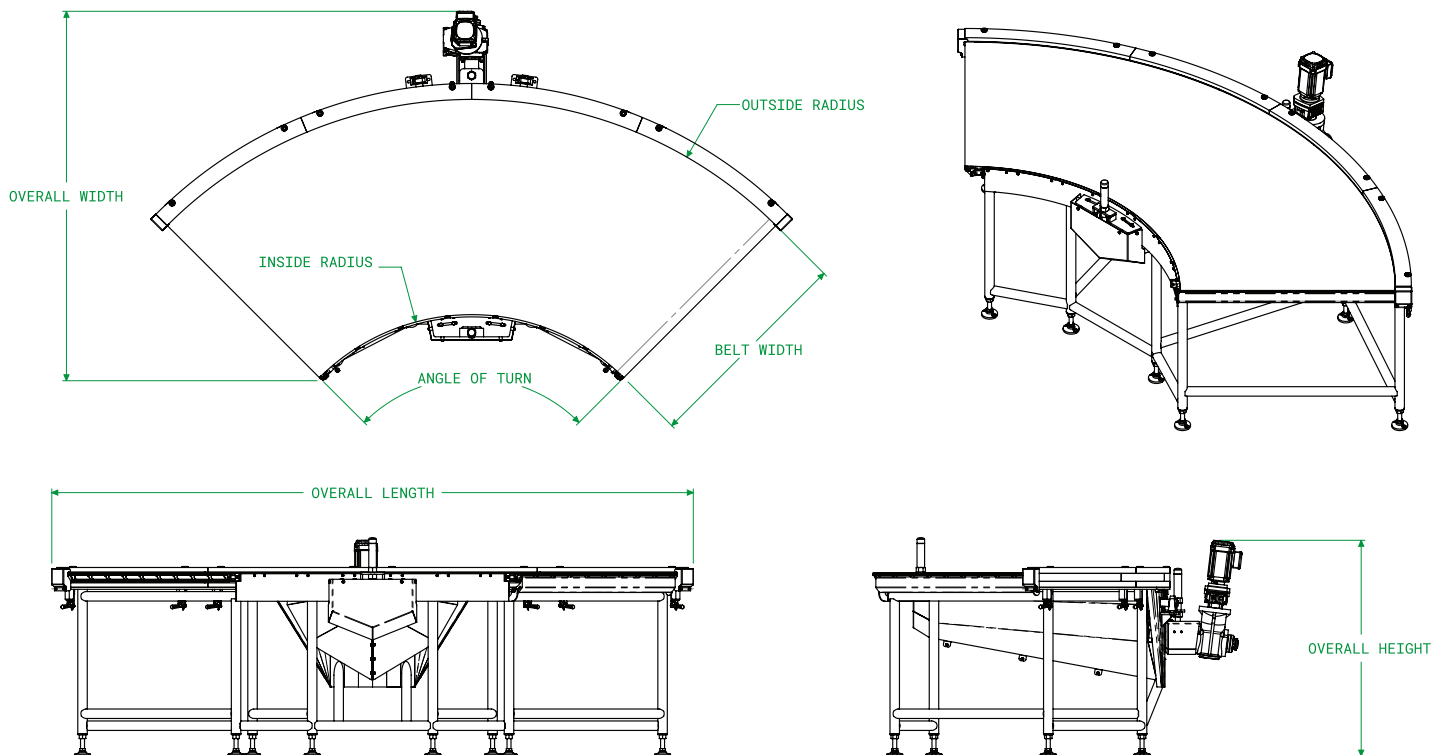

This drawing contains confidential information is the exclusive property of the J.E. Grote Co. Neither this document, nor its contents, are to be used, reproduced or disclosed in whole or in part without the express written permission of the J.E. Grote Co. Copyright 2022, J.E. Grote Company, Inc.

09.22v1

CONTACT US

Ready to get started on your configuration?
Contact us to customize the Curveyor to your application, layout, and processes.



To feed our growing world - Together
sales@pfi conveyors.com
pfi conveyors.com