

# SPREADER CONVEYOR

CONNECT THE VARIOUS WIDTHS  
OF YOUR PROCESSING LINE



The Spreader links the key processes of your line by spreading, diverging, or converging product between wider and more narrow belts. Its positive drive, non-slip stainless steel flex wire chains position product seamlessly, with no jams or pile ups. Tight infeed and outfeed transfers ensure product orientation and integrity. The Spreader is designed for easy sanitation and maintenance.

- Converge, diverge, and spread product between processes
- Positive drive, non-slip flex chains
- Customize infeed and outfeed widths
- Tight transfers for accurate orientation and gentle handling
- Food-grade sanitary design with positive drive system, stainless steel construction

## COMMON FOOD APPLICATIONS



BAKERY



DAIRY



FROZEN



READY-TO-EAT



SNACK FOOD



# SPREADER

## FEATURES + SPECS

Key details to help you decide if the Spreader is right for your operation.

- Positive drive
- Stainless steel
- Locking caster feet
- Chains: stainless steel flex wire, plastic modular

## OPTIONS

Additional equipment options to customize the Spreader precisely to your application.

- Adjustable infeed and discharge widths

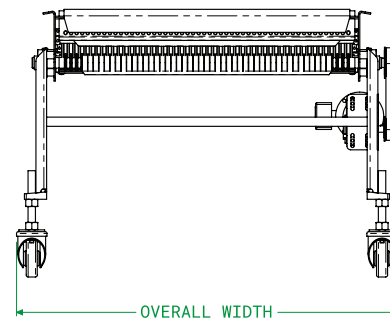
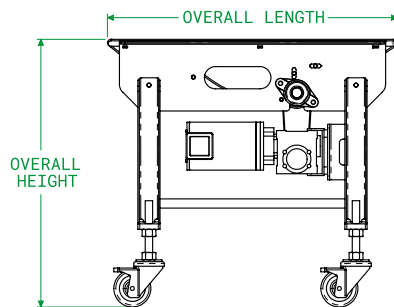
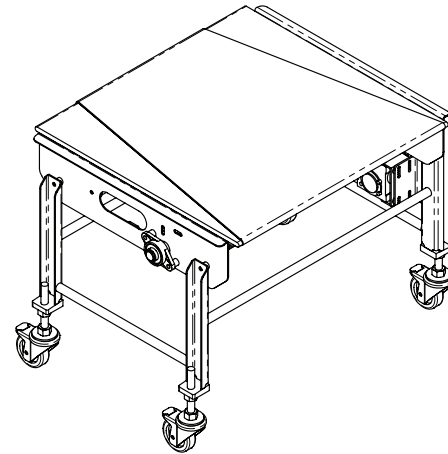
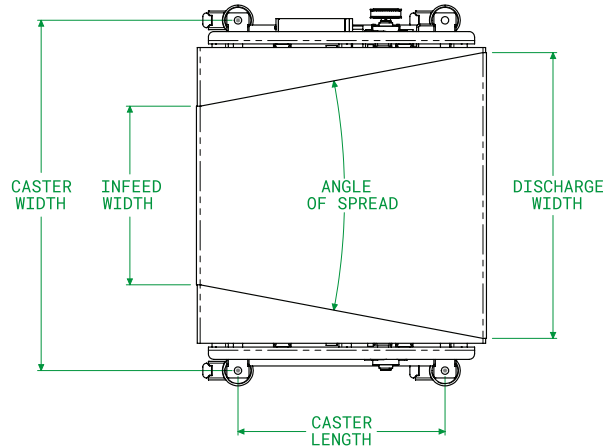

This drawing contains confidential information is the exclusive property of the J.E. Grote Co. Neither this document, nor its contents, are to be used, reproduced or disclosed in whole or in part without the express written permission of the J.E. Grote Co. Copyright 2022, J.E. Grote Company, Inc.

09.22v1

## CONTACT US

Ready to get started on your configuration?  
Contact us to customize the Spreader  
to your application, layout, and processes.



*To feed our growing world - Together*  
sales@pfi conveyors.com  
pfi conveyors.com